

Build a Bluebird Nest Box

Design by Lee Pauser
webmaster@birdsfly.info

Graphics by David Altknecht

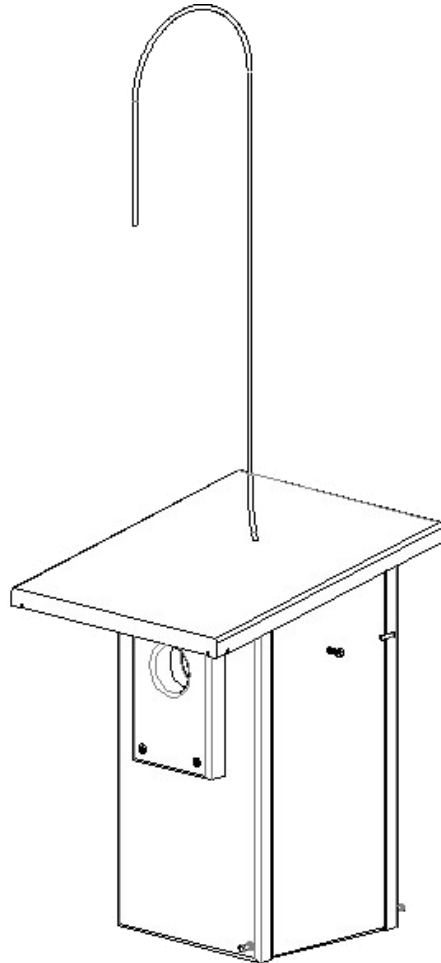

February 4, 2019

Copyright © 2012-2019

The contents of this plan cannot be used for commercial purposes. Non-commercial endeavors may use the plan as long as it remains as a single entity, and proper acknowledgement is given its author.

Foreword

This document provides the information needed to build a hanging bluebird nest box specifically designed for the Western Bluebird, but the design can be scaled for other species and modified to produce a nest box that is to be mounted.

The attributes of the nest box are in large part a compilation of features noted in other designs, and deemed beneficial for a successful nesting experience.

Acknowledgement

This plan would not have been possible without the contributions of David Altknecht who provided the bulk of the graphics herein. Thank you, Dave!

I would also like to thank Chuck Wade who unknowingly provided me the stimulus to author this plan. Chuck has been an active Audubon supporter for years providing it his organizational, hands-on involvement and material support. Chuck is one of the rare individuals that can always be counted on. One example of his willingness to help is that without hesitation he agreed to review and comment on this plan. Thank you, Chuck!

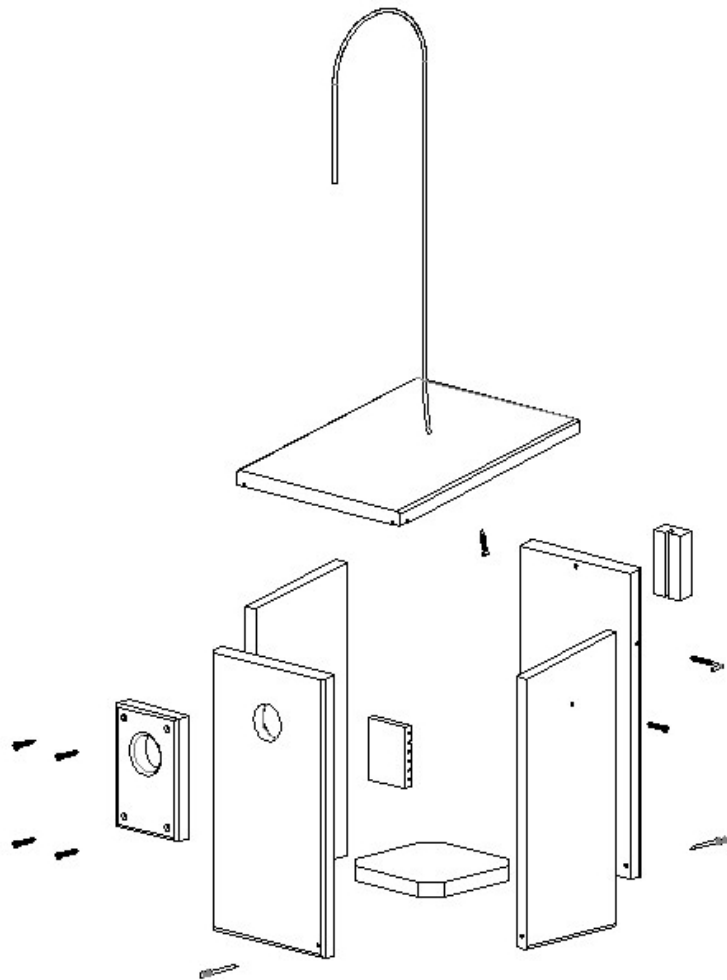

Contents

Foreword2
Acknowledgement2
Introduction4
Required Materials6
Recommended Tools6
Cutlist7
Finishing the Parts8
 Bottom8
 Portal8
 Top9
Front and Back10
 Front10
 Back11
 Final Front and Back Step11
Left and Right Sides12
Hanger Wire Block14
Ladder Block15
Hanger Wire16
Assembly17
 Attach Ladder Block to Front17
 Attach Back to Left Side17
 Attach the Bottom18
 Attach the Front19
 Attach the Right Side (Door)20
 Prepare the Top21
 Align and Attach the Top22
 Hanging Box22
 Mounted Box22
 Secure the Hanger Wire23
 Attach the Portal24
 Install Door Pull24
 Install Door Stop and Lock Screws25
 Form the Hanger Wire’s Hook26
 Check the Box27
 Seal the Box27
The Payoff28

Introduction

There are many designs for nest boxes available, so why is this design better?

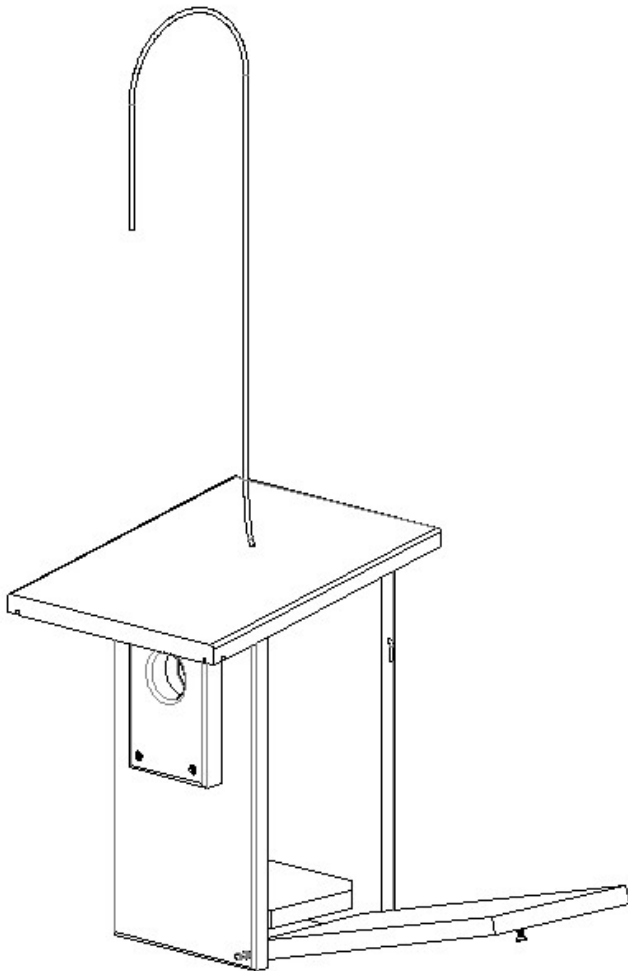

1. It's a hanging box which provides the advantage of easy installation (this assumes that a suitable tree is available), and portability. Once suspended in a tree, the box will benefit from the tree's shade which will keep the interior of the box cooler which in turn reduces the loss of nestlings during periods of extreme high temperatures. A hanging box also provides increased protection from predators.
2. The box is side-opening with the opening side being bottom hinged. This allows a monitor easy access to the inside of the box. By slightly opening the side, a monitor can quickly ascertain the box's contents, and proceed accordingly. A side opening box also provides a secondary and easy exit for any bird wanting to exit the box.
3. The box has flow-through ventilation (not obvious in the drawing) which also helps to keep the box's interior cooler. The ventilation is enabled by $\frac{1}{2}$ " gaps at the top edge of both sides.
4. Drip guards cut into the top's underside prevent wind-driven rain from migrating into the box's interior. During periods of inclement weather, nestlings can die from hypothermia should they get wet.
5. Corners cut off the box's bottom provide drainage should water enter the box.

6. A portal or predator guard over the entrance hole inhibits predation by putting the interior of the box out of reach for most predators.
7. The roof's extended over-hang also provides increased protection from predators that may be positioned on the roof.
8. A ladder block which enables the nestlings to more easily climb to the entrance hole and provides a perch that is more recessed than the entrance hole itself providing nestlings additional protection.
9. Lastly, the box is made from 5/8" thick exterior grade (CDX) plywood. Plywood frees a builder from the constraints imposed by the dimensions of stock lumber (e.g. the stock's width limiting the box's outside dimensions which imposes a floor size of less than 5" x 5"). Nest boxes made from exterior grade plywood will provide many years of use in a woodpecker free environment.

This nest box is more difficult to build than most other styles, but the advantages provided outweigh the added effort.

Required Materials

The below list identifies the materials needed to build 9 nest boxes.

- One 4' x 8' sheet of 5/8" thick CDX rated (exterior grade) plywood
- Titebond III Ultimate Wood Glue
- 1-1/2" brad nails¹ (approximately 200)
- 1" brad nails¹ (approximately 60)
- 9 1-5/8" long square bend screws (used to lock doors closed)
- 9 1" exterior wood screw (used for door pulls, and to attach the portals)
- 9 1-1/4" exterior wood screw (used as door stops)
- 18 Double-headed or duplex nails (used as hinge pins)
- 9 48" lengths of 9 gauge tension wire²
- One tube of silicone sealant (GE Premium Waterproof Silicone)

Recommended Tools

- Pencil
- Brad nailer¹
- Power drill driver or Phillips screw driver
- A drill and bits
- 1-9/16" Forstner Bit
- Tapered Countersink Bit
- Tape measure
- Table saw
- Router with 1/8" roundover bit
- Pliers
- Hammer
- For hanging nest boxes, a hacksaw to cut wire.
- For hanging nest boxes, a drill brace to twist the hanger wire.

¹ A brad nailer is used to tack the boxes together while the wood glue sets. Once set, the wood glue primarily holds the box together. Other approaches can be used in lieu of a nailer such as wood screws or nails, however, steps must be taken to avoid splitting the wood.

² This 9 gauge wire is normally used as a tension wire to stabilize chain link fencing.

Cutlist

The below cutlist and parts list provide information on how to optimally cut the parts for 9 boxes from a single sheet of 4' x 8' plywood. The following steps assume that you have rough cut the parts using the below cutlist.

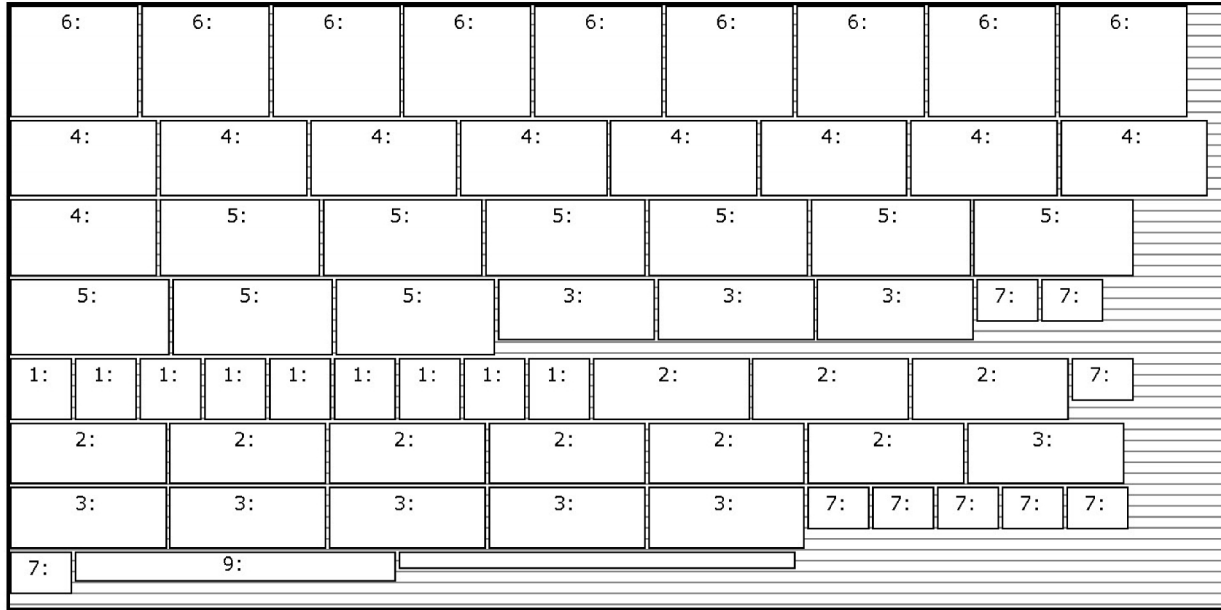

<i>Part #</i>	<i>Description</i>	<i>Copies</i>	<i>Rough Y Dimension</i>	<i>Rough X Dimension</i>
1	Bottom	9	5"	5"
2	Right Side	9	5"	12-1/2"
3	Left Side	9	5"	12-1/2"
4	Front Side	9	6-3/16"	11-3/4"
5	Back Side	9	6-3/16"	12-3/4"
6	Top	9	9"	10-1/4"
7	Portal	9	3-1/2"	5"
8 ³	Hanger Wire Blocks	1	1-1/2"	31-1/2"
9 ³	Ladder Blocks	1	2-1/2"	25-1/2"

³ This strip will later be cut into 9 separate blocks.

Finishing the Parts

Before beginning assembly, finish the following parts as shown. Some parts have their edges rounded using a router with a 1/8" roundover bit to provide a finished look.

Bottom

The corners of the bottom are cut off to provide for drainage.

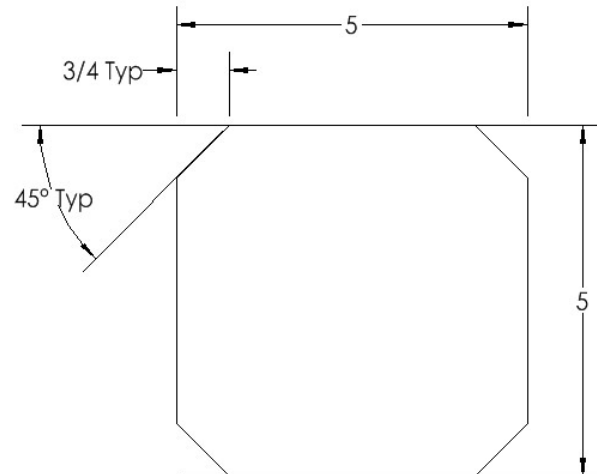

Portal

Finishing the portal involves:

- Drilling four 5/32" holes through the portal for the mounting screws. These holes should be counter-sunk so the tops of the screws will be flush with the portal.
- Drilling the entrance hole. A 1-9/16" Forstner Bit provides a smooth finished hole.
- Rounding the portal's outward facing edges.

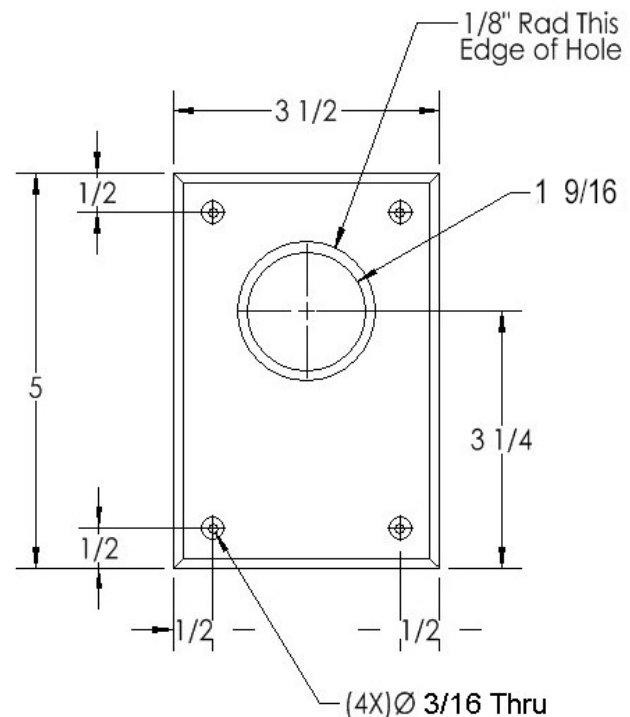

Top

The top requires:

- The front and back edges to be cut at a 10 degree angle.
- The two drip guards to be cut.
- The upper side and back edges to be rounded.
- If the box is to be a hanging box, a hole to be drilled near the center of the top for the hanger wire. The diameter of this hole should be slightly larger than the diameter of the hanger wire-- $11/64$ ".
- The door stop screw should be added in the final assembly steps.

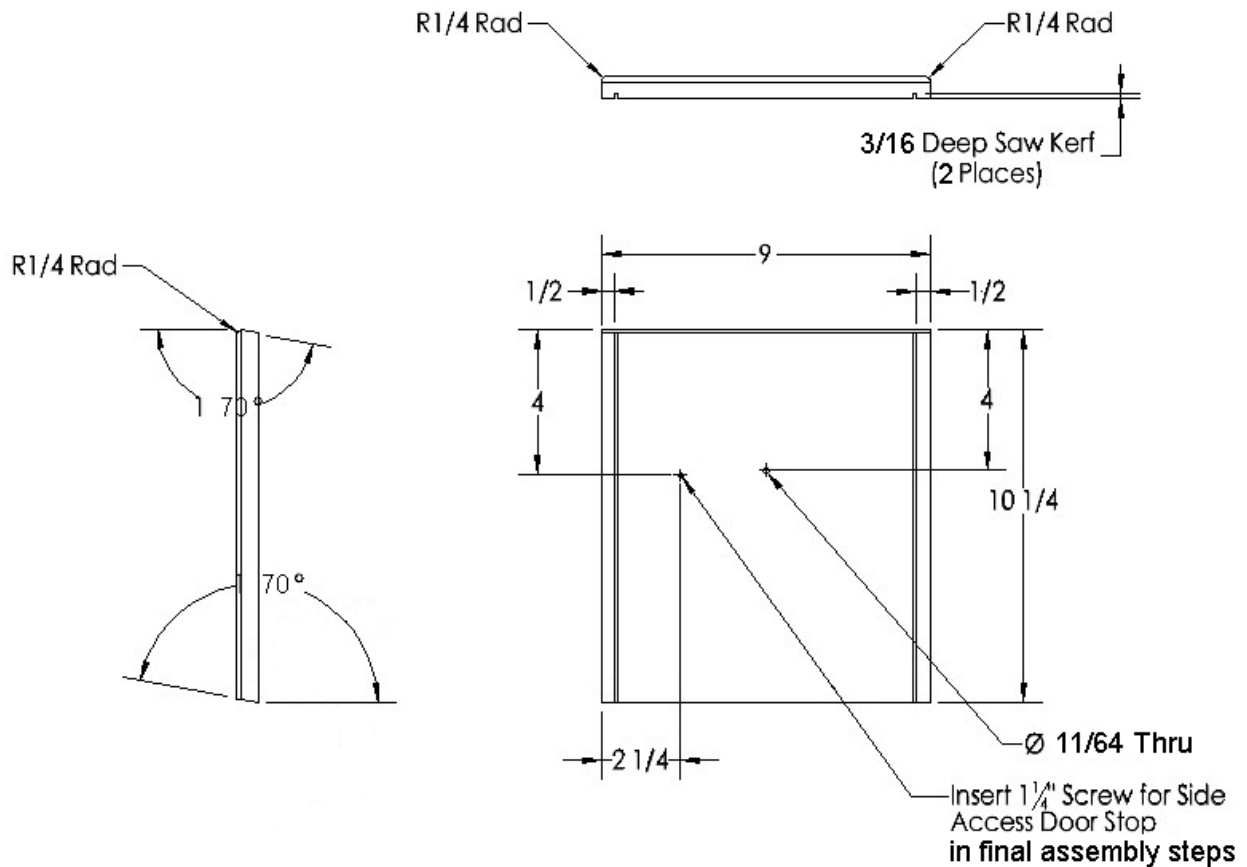

Front and Back

It is beneficial to inspect and pair the rough cut parts to decide which part and side would best suited where. Consideration should be given to the parts that will be hinged to the right side near its bottom edge—knots or material faults can negate adequate material for proper hinge installation. Also, which side of the part has the better appearance—place the better looking side out.

Front

Finishing the front will involve:

- Cutting the front to length at the angle indicated.
- Drilling the entrance hole. A 1-9/16" Forstner Bit provides a smooth and finished hole.
- Rounding the edges as indicated.

Note: Defer drilling the hinge nail's hole for now.

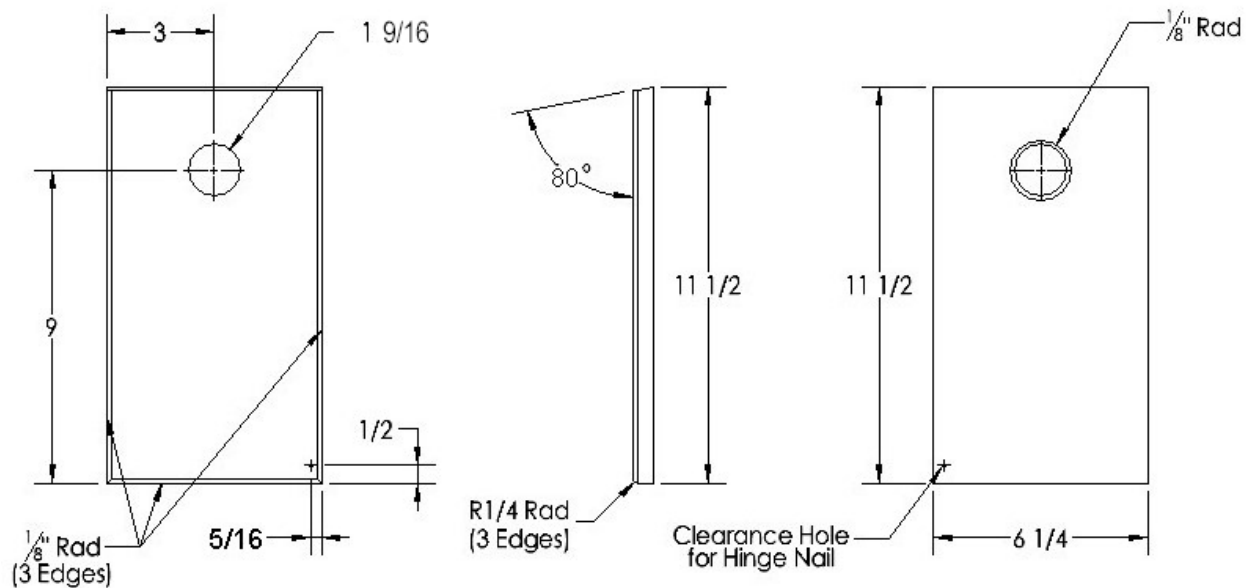

Back

Finishing the back will involve:

- Cutting the top to length at the angle indicated.
- If the box is to be a hanging box, a hole to be drilled for the hanger wire. The diameter of this hole should be slightly larger than the diameter of the hanger wire.
- Rounding the edges as indicated.

Note: Defer drilling the hinge nails and L-screws holes for now.

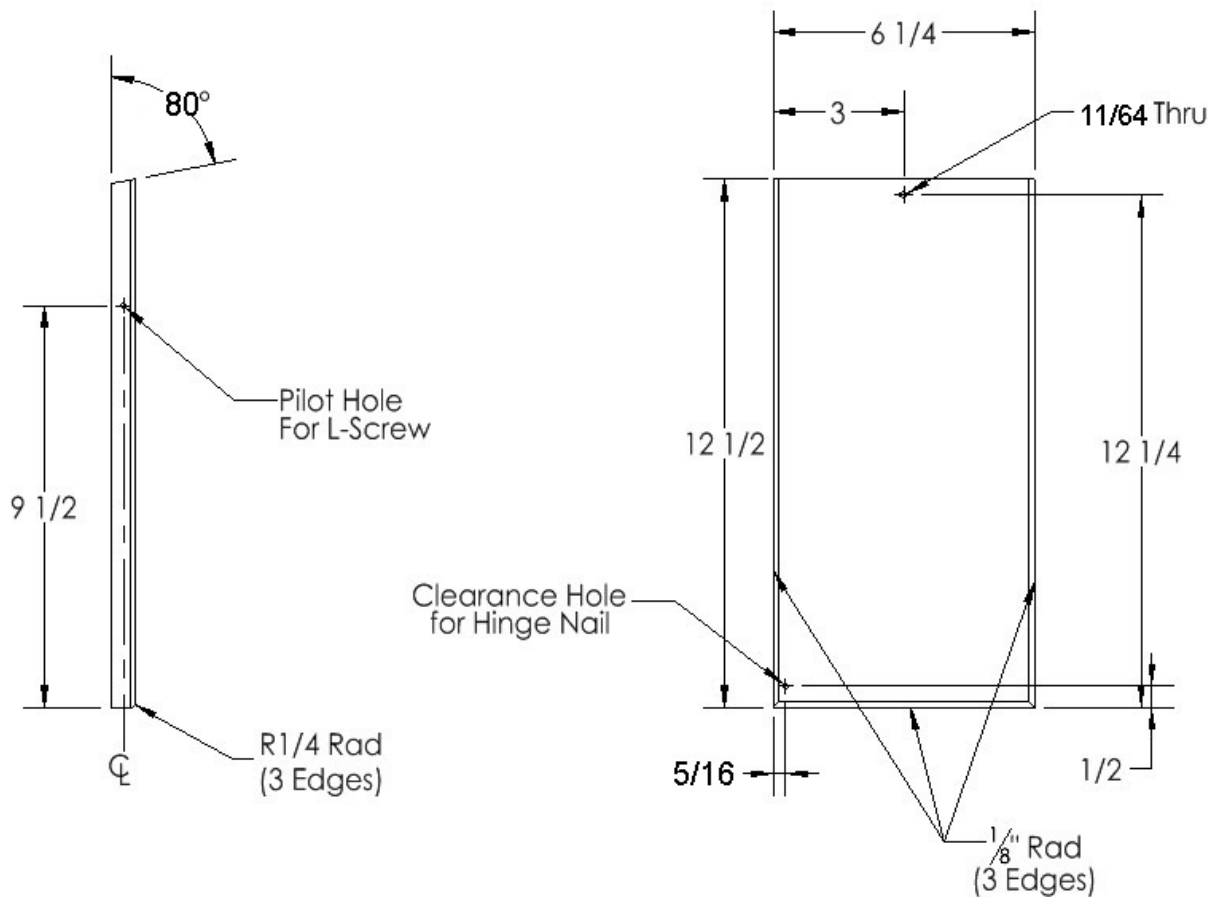

Final Front and Back Step

Pair the front and back together then drill the holes in the front and back for the double-headed hinge nail at the same time. The diameter of these holes should be slightly larger than the diameter of the nail so the hinge will operate smoothly.

Left and Right Sides

As with the front and back, it is beneficial to inspect and pair the rough cut parts to decide which part and side would best suited where. Consideration should be given to the parts that will become the right side which will be hinged near its bottom edge—knots or material faults can negate adequate material for proper hinge installation. Also, which side of the part has the better appearance—place the better looking side out.

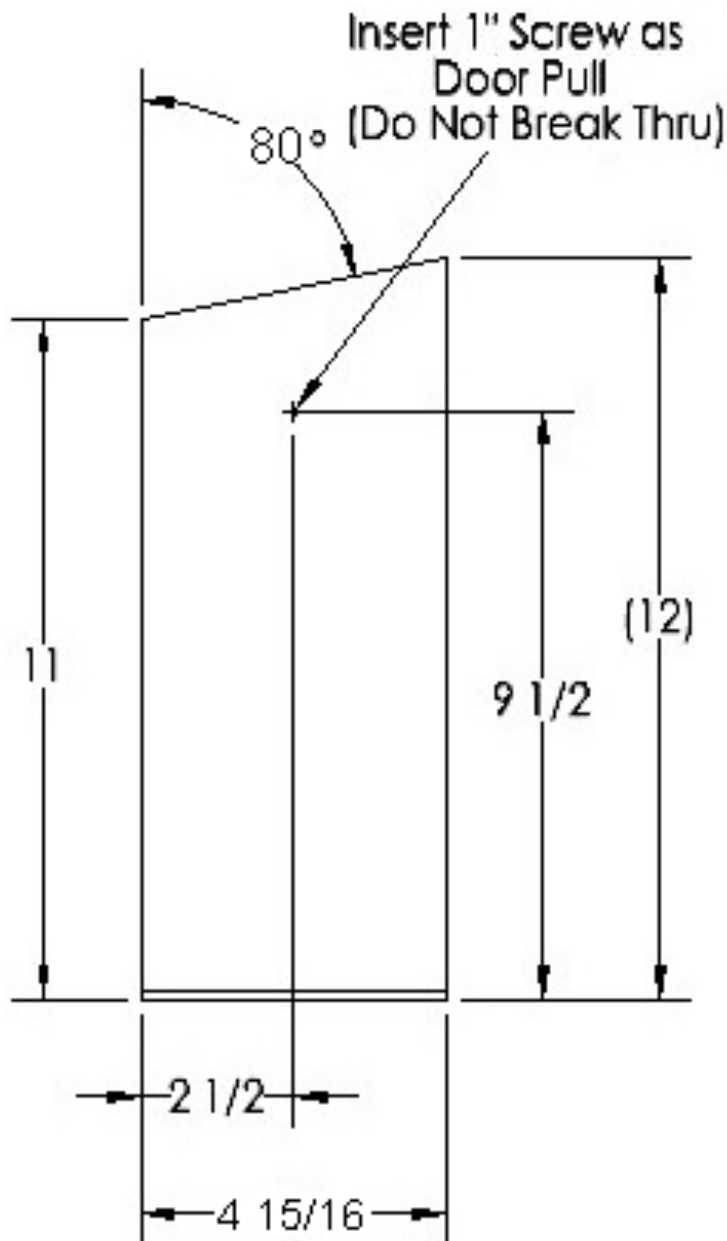

The left and right sides are finished almost identically. The only difference is that the left side will have a width of 5", and the right side a width of 4-15/16" plus having a door pull.

Note that it is the right side that is pictured—the right side has a width of 4 15/16", and a door pull screw. Although the screw's location is shown, defer installing it until a later step.

At this point it is advised to determine the exact angle that the top of the sides are to be cut off. Eighty degrees is the expected angle, but other factors can change the exact angle.

To determine the exact angle, temporarily set a top, back, and left side together as if assembled. Using a straight edge placed on the upper top and back edges and next to the left side's top. Draw a pencil line on the side. The left and right sides are to be cut $\frac{1}{2}$ " below this line to provide the ventilation gaps.



Having verified the angle of the cut, prepare to cut a pair of sides (left and right) by facing the good sides of each side outward, and laying the pair against the saw's miter gauge and fence. Align the pair's edges, and cut the tops of both sides at the same time.

Cut the right side to a width of $4\text{-}\frac{15}{16}$ ".

Lastly, round the sides' outside bottom edges.

Hanger Wire Block

The hanger wire block is only needed if the box is to be a hanging box. If the box is to be a mounted box, skip this step.

Caution should be used when cutting small parts such as this. It is advised to:

1. Initially cut a single strip of plywood that is $1\frac{1}{2}$ " wide, and long enough to provide the total number of blocks plus additional material which will allow for handling the material right up through the time that the last block is cut out.
2. Cut the wire hanger slot into the strip as indicated below.
3. Cut to length the required number of hanger blocks being especially careful while the last blocks are cut.

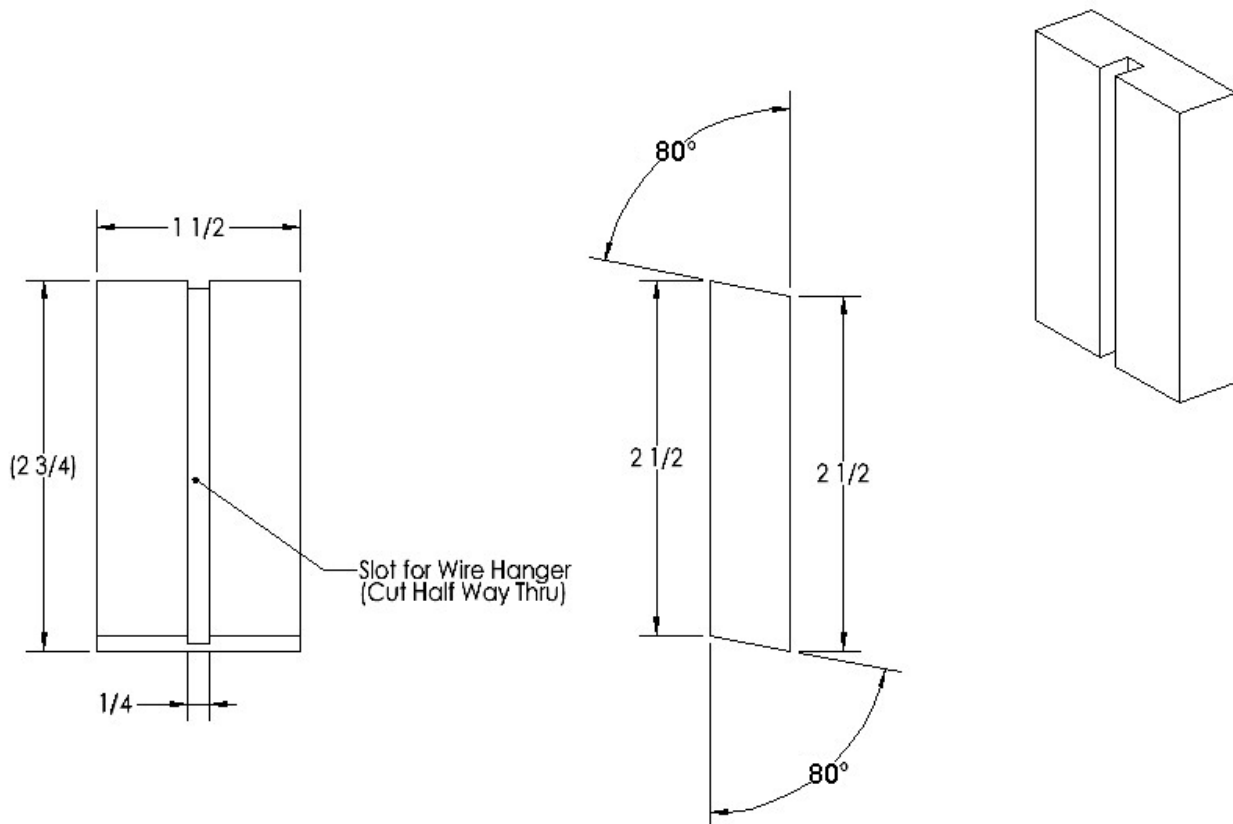

Ladder Block

Caution should be used when cutting small parts such as this. It is advised to:

1. Initially cut a single strip of plywood that is $2\frac{1}{2}$ " wide and long enough to provide the total number of blocks plus additional material which will allow for handling the material right up through the time that the last block is cut out.
2. Cut the block's six slots to a depth of $\frac{5}{16}$ " into the strip as indicated below.
3. Cut to width the required number of ladder blocks being especially careful while the last blocks are cut.

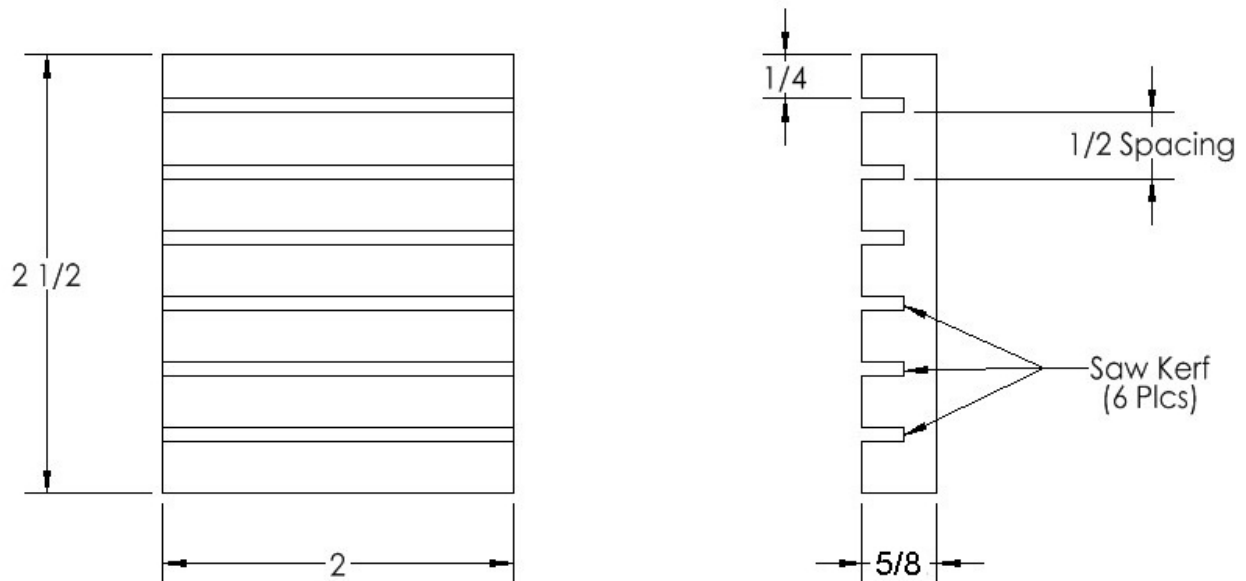

Hanger Wire

The hanger wire is only needed if the box is to be a hanging box. If the box is to be a mounted box, skip this step.

Each hanger wire is made from a 48" length of 9 gauge tension wire. Although the wire is stiff, the hook portion of the wire is doubled and twisted to insure that the hook doesn't straighten due to the box's weight, severe weather buffeting, or vandalism.



To finish the hanger:

1. cut 48" length of wire
2. at 16" fold one end of the wire over onto itself
3. clamp the end of the 16" section and the longer section tightly together in a large vice (5" or larger)
4. insert and tightly lock the folded end into the jaws of a brace drill
5. quickly turn the handle of the drill numerous times to twist the wire on itself.

Assembly

Attach Ladder Block to Front

Put a spot of glue on the back side of the ladder block, center the block with the kerf cuts horizontally $\frac{1}{2}$ " below the entrance hole on the inside side of the front, and tack it with two 1" brads.

Attach Back to Left Side

Place the left side on the work surface with front edge down. Apply glue to the side's back edge. To provide temporary stability, place the bottom next to the left side's inside as pictured.

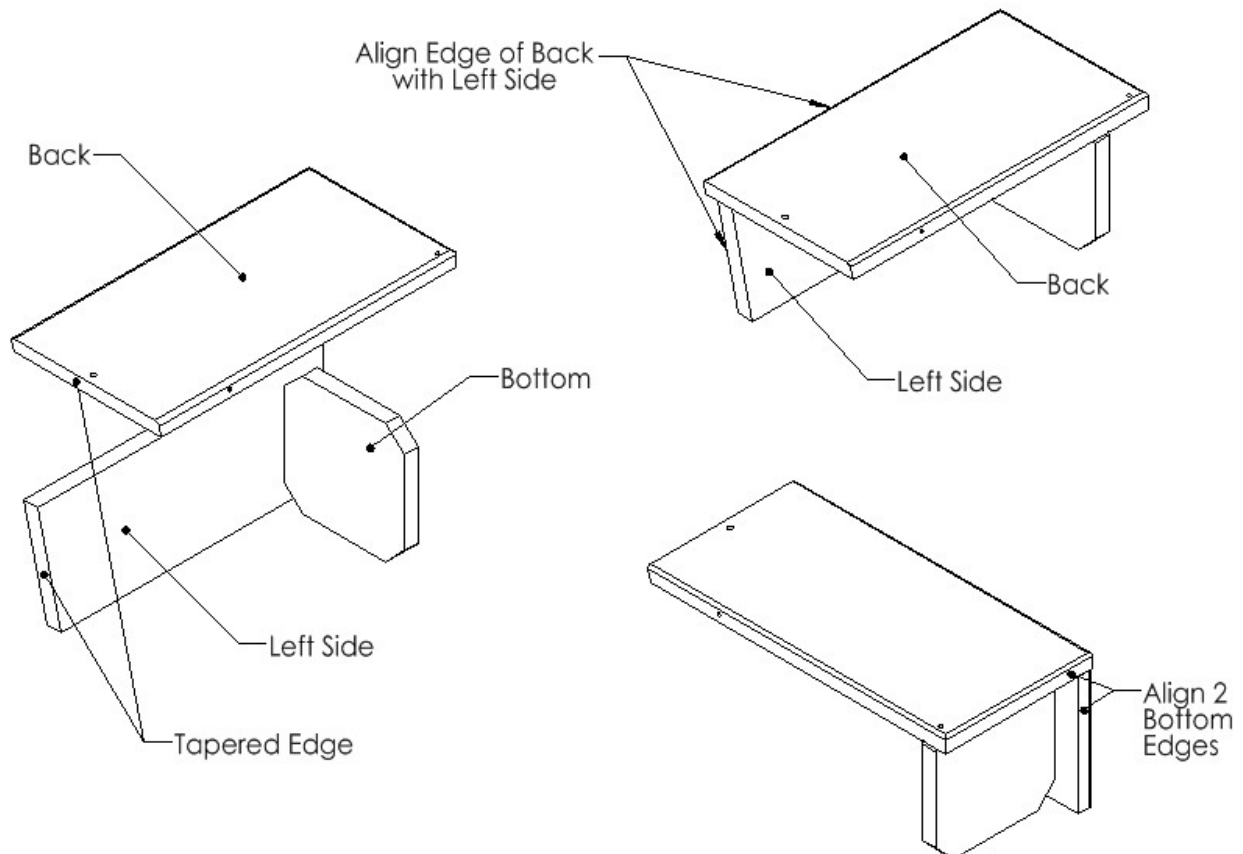

After positioning the parts, tack the back to the left side.

Attach the Bottom

A 1" thick spacer block is useful in positioning the bottom as shown. (It is important that the bottom's underside be 1" from the box's bottom edge to insure that the side door can be fully opened.)

Apply glue to 2 edges of the bottom, position the bottom, and Tack it to the back and left side.

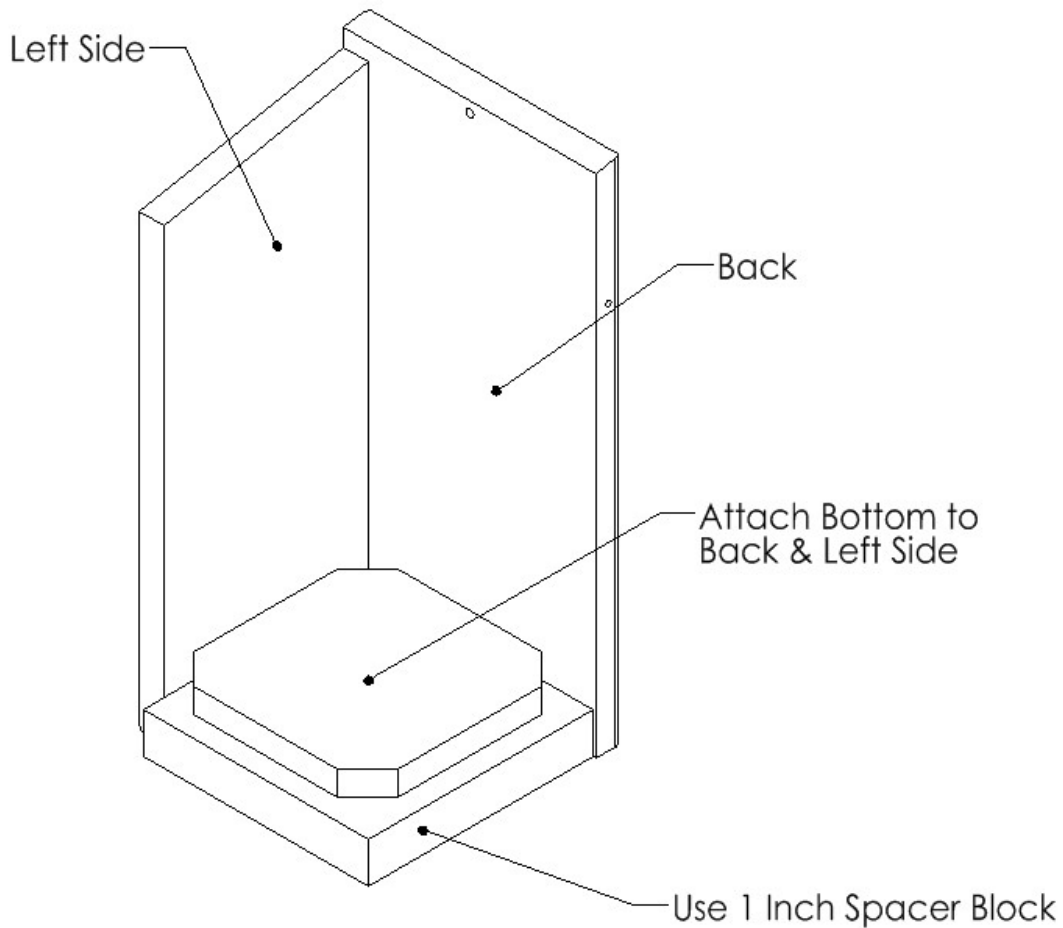

Attach the Front

Lay the assembled parts on the work surface as shown. Apply glue to the upright bottom's and side's edges. Align the front as shown, and Tack it to the assembly.

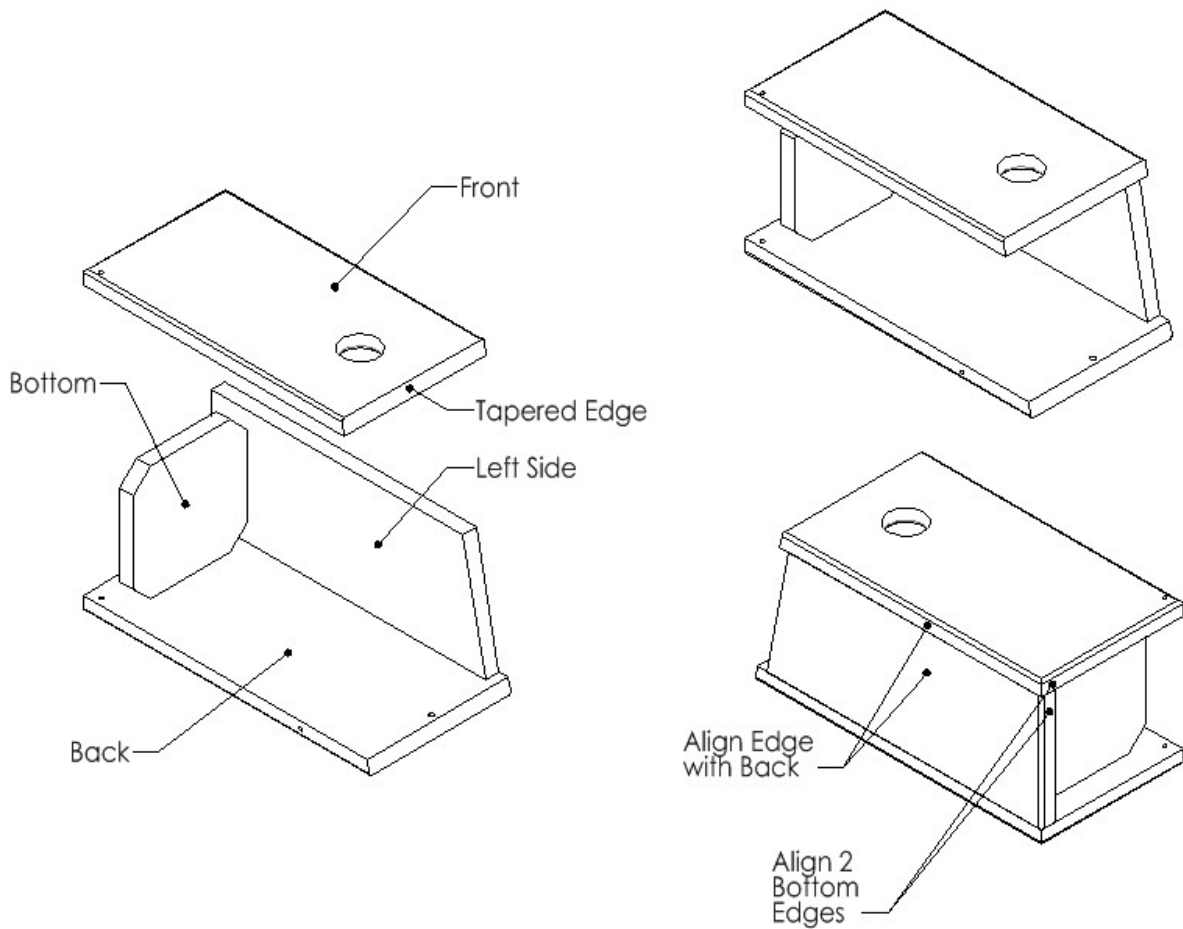

Attach the Right Side (Door)

Position the assembly front side up on the work surface. Position the right side in place, and drill one hole through the front's double-headed nail hole, and into the right side. For a snug fit, the diameter of the hole should be slightly less than the diameter of the nails. To avoid splitting the side, insure that you drill to a depth equal to the driven length of the nail. Carefully drive one nail into the just-drilled hole.

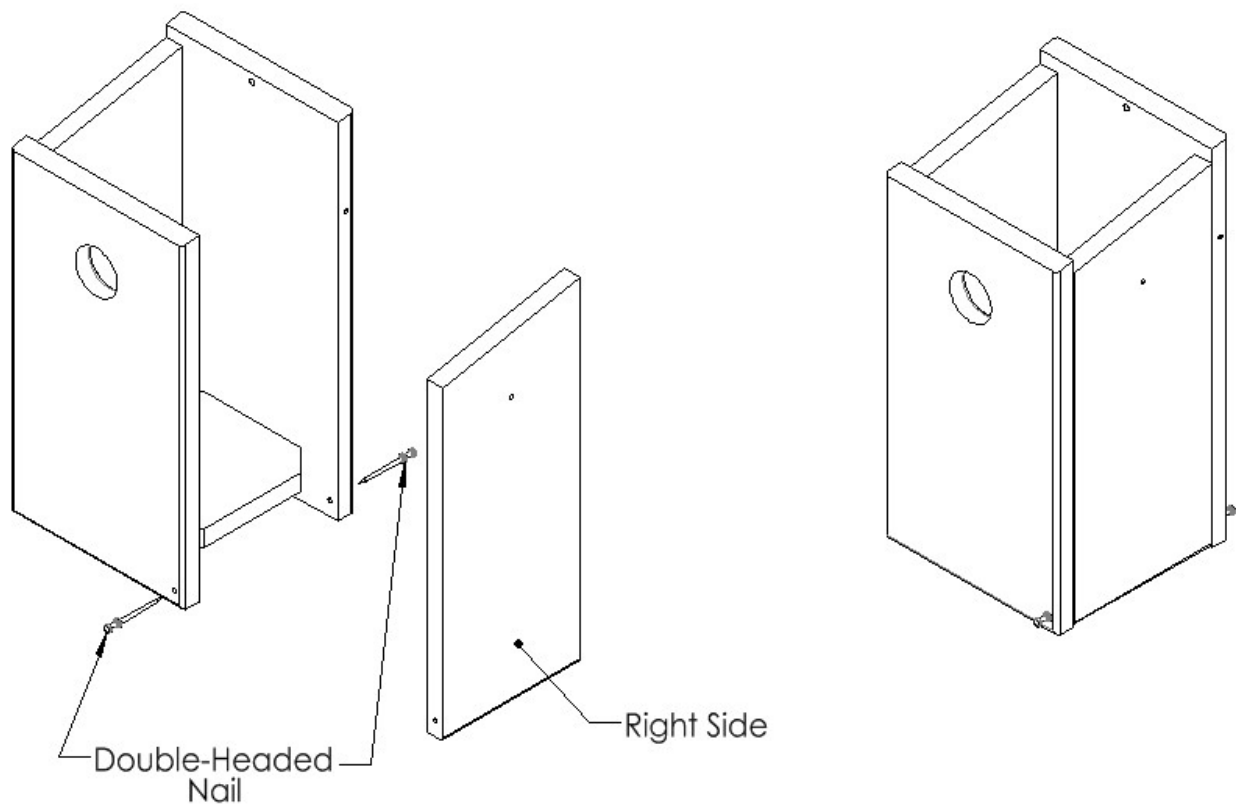

Turn the assembly over, and execute the procedure again to secure the right side to the back.

Prepare the Top

This step is only needed if the box is to be a hanging box. If the box is to be a mounted box, skip this step.

Stand the assembly upright on the work surface. Insert a hanger wire through the top and bend it as shown. Apply glue to the top edges of the front and back. Feed the bent end of the wire through the hole in the back.

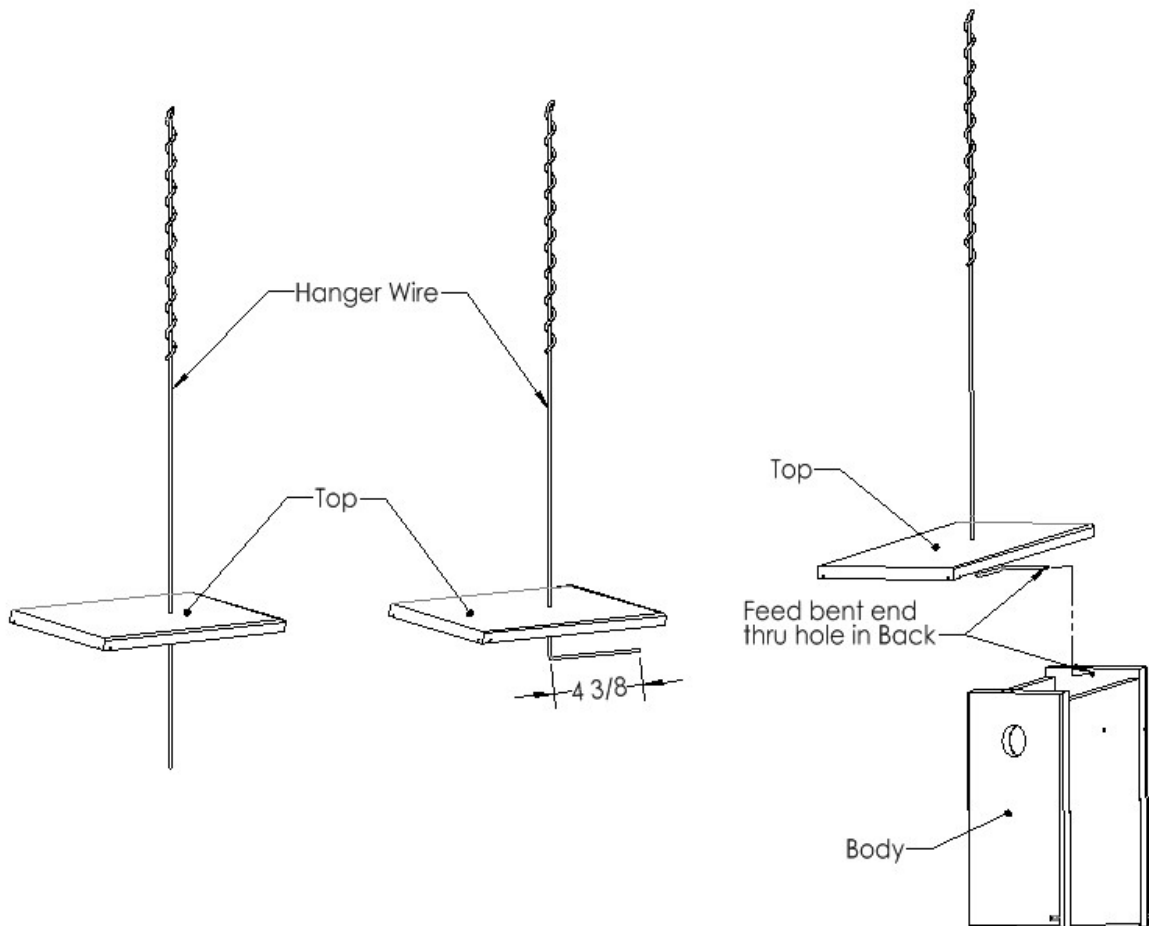

Align and Attach the Top

Hanging Box

After applying glue to the front's and back's edges, align the top to the assembly as shown below, and Tack it to the assembly.

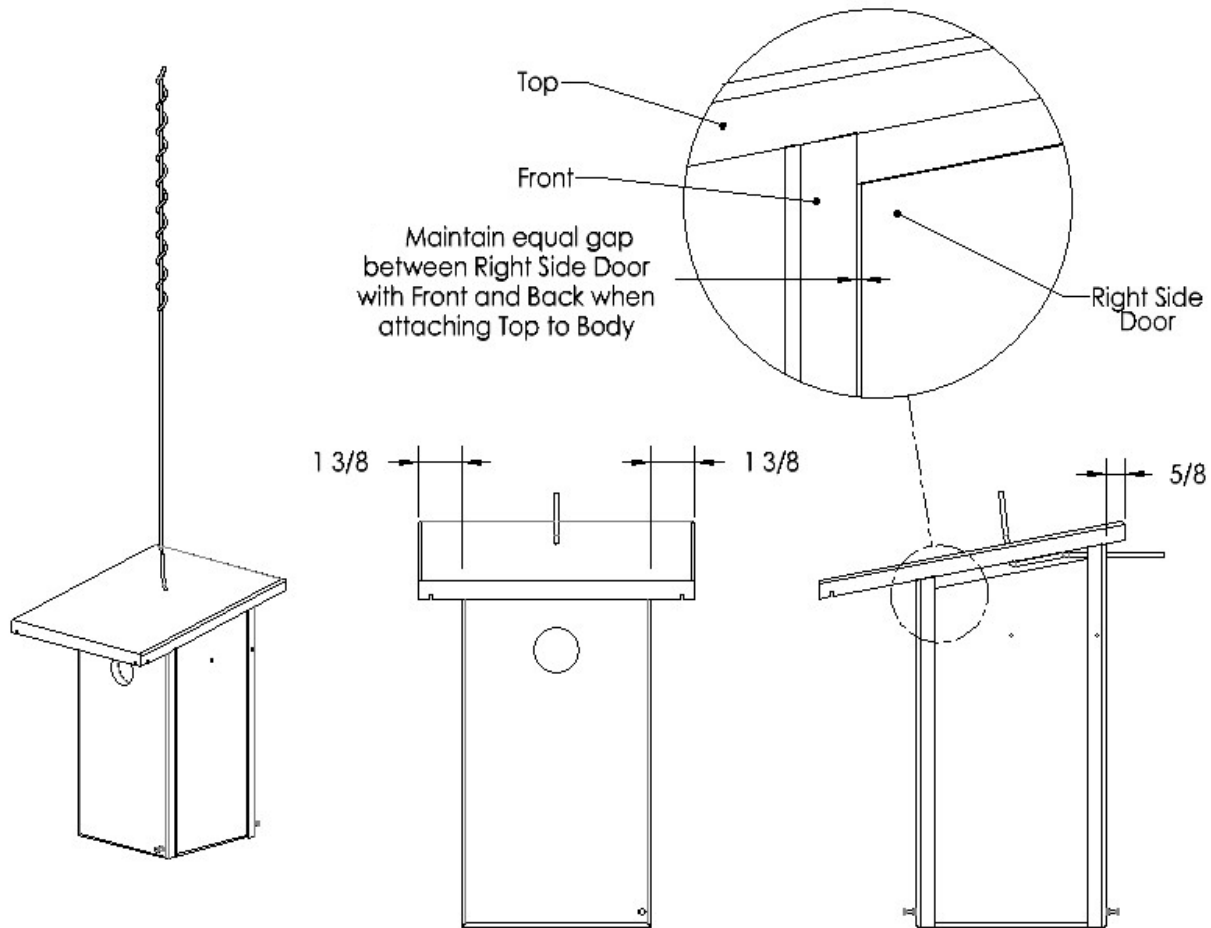

Mounted Box

After applying glue to the front's and back's edges, align the top's back edge flush and centered with the back. As pictured above, you should maintain an equal gap on both side edges of the right side. Failure to do so could cause the side to bind.

Once alignment is proper, Tack the top to the assembly.

Secure the Hanger Wire

This step is only needed if the box is to be a hanging box. If the box is to be a mounted box, skip this step.

Bend the end of the hanger wire as shown. Apply glue to the Hanger Wire Block, position the block over the wire and snug it against the top. Tack the block to the back using four 1" long brad nails.

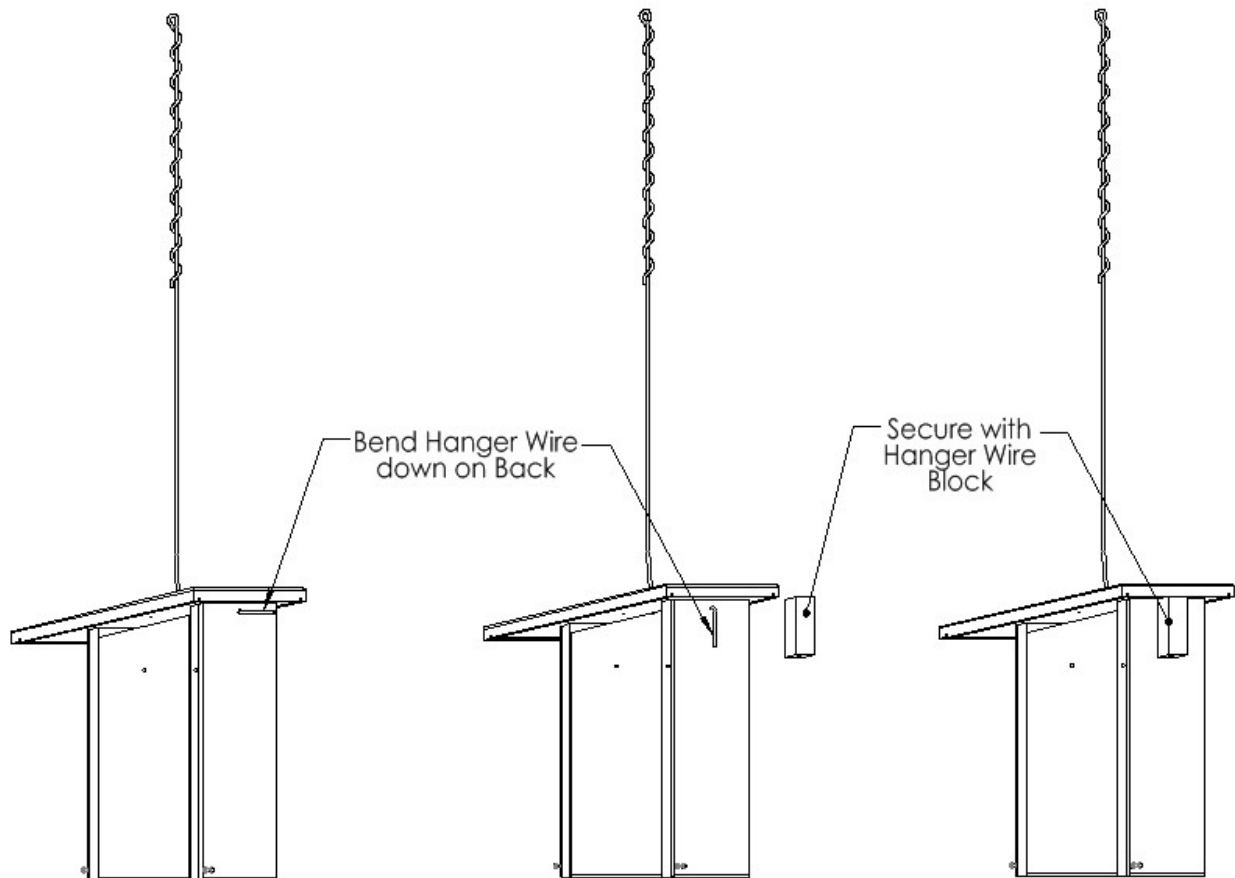

Open the side of the box, turn the box upside, place the top on the edge of the work surface, and, using a small hammer, form the wire inside the box as close to the top as possible so that the gap between the wire and top is minimal.

Attach the Portal

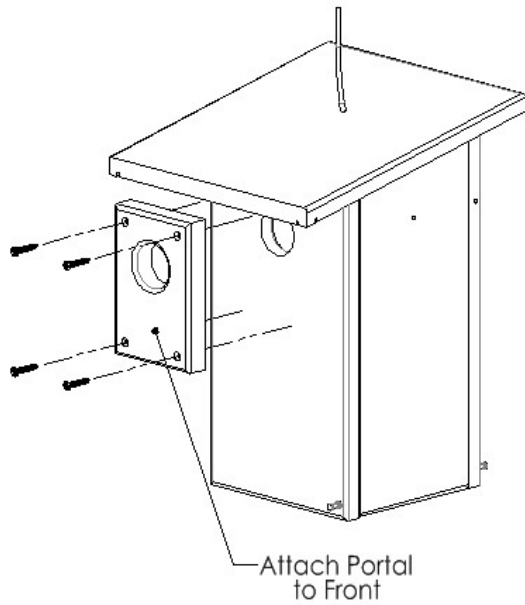

Align the portal on the assembly's front, and attach it using 4 1" long screws. The portal is not glued allowing it to be replaced should circumstances require it.

Install Door Pull

Partially insert a 1" long screw into the right side as shown. This screw will serve as a door pull.

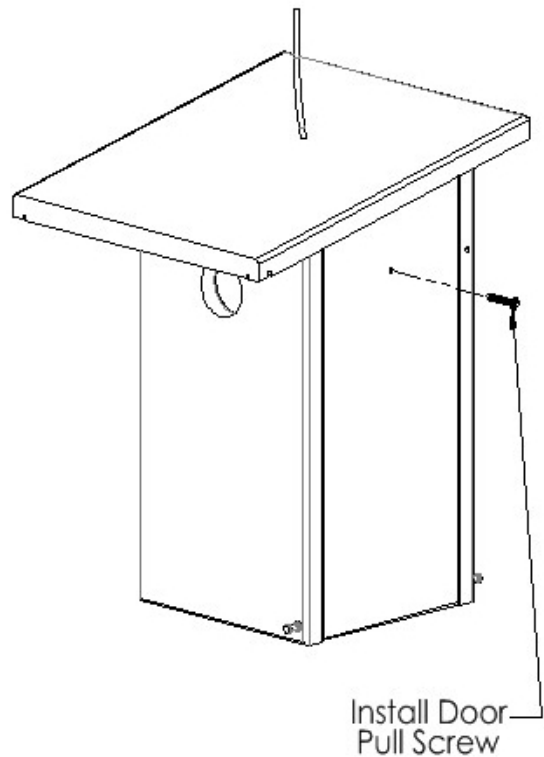

Install Door Stop and Lock Screws

Install a 1-14/” screw into the underside of the top for the door stop. When properly installed. The door will be tight and flush with the front’s and back’s edges when the door is closed.

Drill a hole into the back’s right edge for the door lock. The hole’s diameter should be slightly less than the diameter of the lock screw (square bend screw). Insure that the depth of the hole equals the length of the lock screw’s threaded end (1-5/8”). Insert the lock screw.

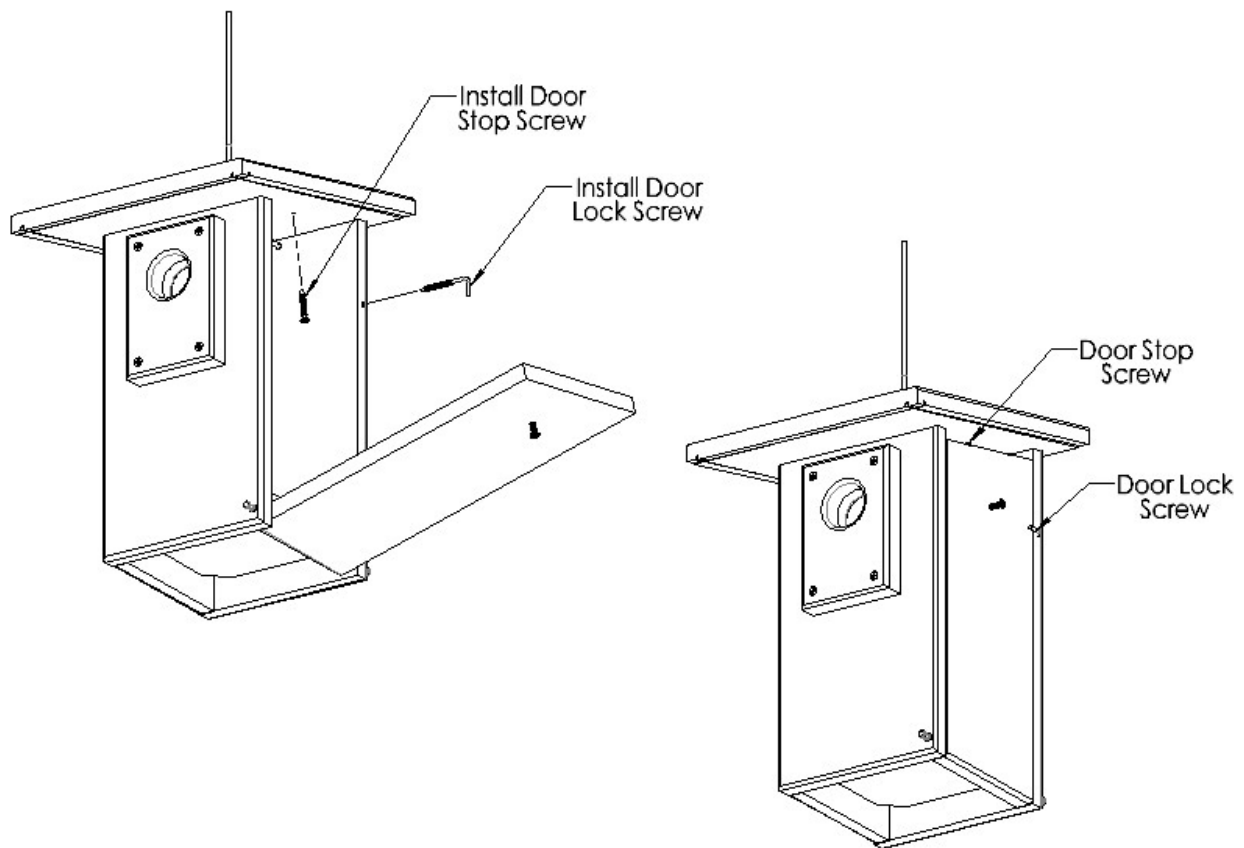

Form the Hanger Wire's Hook

This step is only needed if the box is to be a hanging box. If the box is to be a mounted box, skip this step.

Form the doubled portion of the hanger wire into a hook.

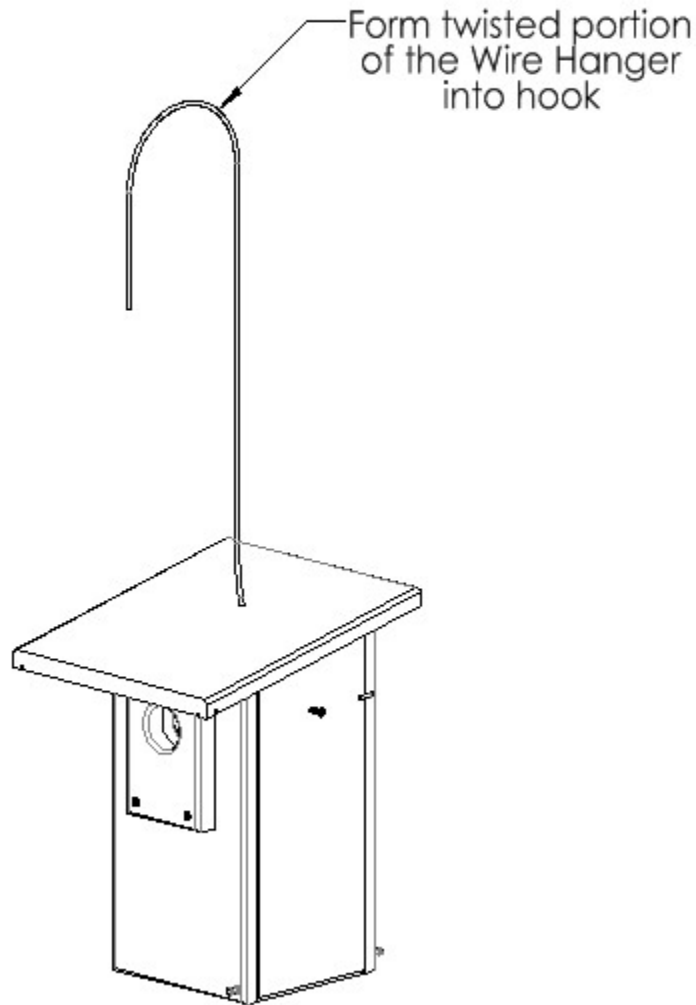

Prior to actually hanging the box, the hook should be reformed to be slightly larger than the branch from which the box will hang with the hook's depth sufficient to prevent the box from dropping. Additionally, the hook can be turned so that the box faces in the desired direction and can be easily installed and retrieved.

Check the Box

At this point a few checks should be made:

1. Inspect the inside of the box to insure that there isn't anything sharp protruding that could injure the inhabitants. Look for splinters of wood, or brad nails that took an unexpected turn. Remove, bend or cut off the protrusion.
2. Open and close the side door to insure that it doesn't bind. As designed, the door's total clearance is just 1/16", and due to material warping or inaccurate cutting the door may bind or rub on the front/back. During periods of rain some swelling of these parts is normal which further aggravates any binding. If binding is observed, remove the door and trim its width slightly. Install and test the door again. Trim again if necessary.

Seal the Box

As a final step, seal the box using silicone sealant. Points to seal include:

- If the box has a hanger wire, seal the area around the wire where it passes through the top's outside.
- The outside back of the box where the top and back meet.
- Any opening in the exposed plywood due missing layers or knots.

The Payoff

Seven Western Bluebird eggs



Five just hatched Western Bluebirds

Five 21 day-old Western Bluebird nestlings

